

SMHW40E

SANY

Quality Changes the World



POWERING THE FUTURE

PERFORMANCE, SUSTAINABILITY, INNOVATION



BATTERY MATERIAL HANDLER
SMHW40E

Battery capacity
507 kWh
Main drive
160 kWh
Swing drive
80 kWh
Loading equipment
15 – 17 m

BATTERY MATERIAL HANDLER

- + High efficient drive modes
- + Less maintenance requirements
- + Fast charging with dual gun
- + Reduced noise level

Battery capacity
507 kWh
Main drive
160 kWh
Swing drive
80 kWh
Loading equipment
15 – 17 m



BATTERY

Type	Lithium ferrophosphate
Capacity	80 kW / 400 Nm
Warranty period	The attenuation in 5 years shall not exceed 30%
Full discharge cycles	>2800
Cooling mode	liquid
Continuous working time	6–8 h

CHARGER

Charging duration	80 – 120 Minutes
Charging power	2x 150 kW/h

ELECTRIC MOTORS

Main drive	160 kWh / 750 Nm
Swing drive	80 kWh / 400 Nm

HYDRAULIC SYSTEM

Hydraulic pressure	343 bar
Max. oil flow	1x 360 l/min, 1x 380 l/min
Filling quantity of the hyd. system	320 l
Swing speed	8 rpm

CABINE

Lifting range	2650 mm
Eye level	5800 mm

LOADING EQUIPMENT

Arm	Boom	Stick
15 m	8.9 m	6.5 m
17 m	9.8 m	7.5 m

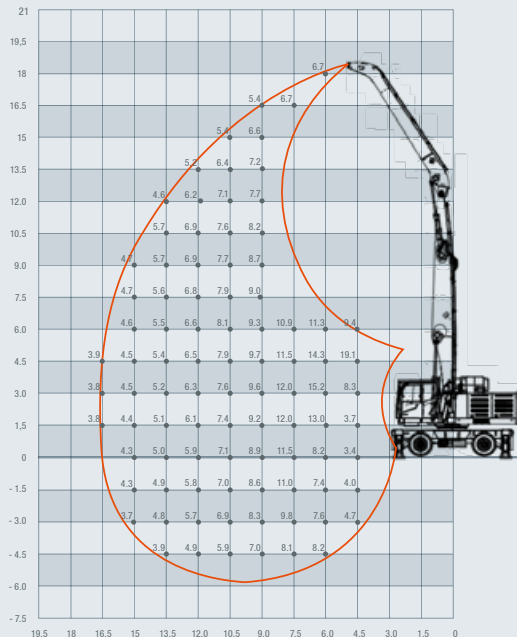

Arm: **17 m**
Boom: **9.8 m**
Stick: **7.5 m**

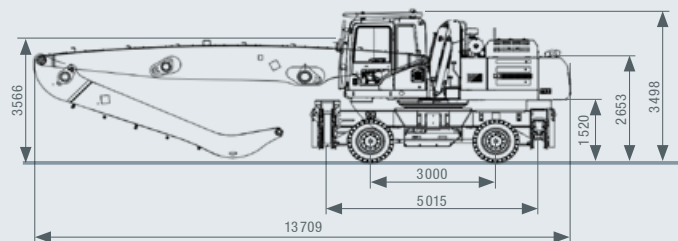

Not all products are available in all markets. As part of our continuous improvement process, we reserve the right to modify specifications and designs without giving prior notice. The figures may contain additional options.

SANY

Quality Changes the World

SANY EUROPE GmbH
Sany Allee 1
D-50181 Bedburg
Tel. +49 2272 90531 100
Fax +49 2272 90531 109
info@sanyeurope.com
www.sanyeurope.com